

Projects

Commercial & Retail

Hotel Resort & Restaurant

Religious

Medical

Residential



The Mills Creek Industrial Complex

City of Hamilton



The Greymane Bldg

City of Hamilton



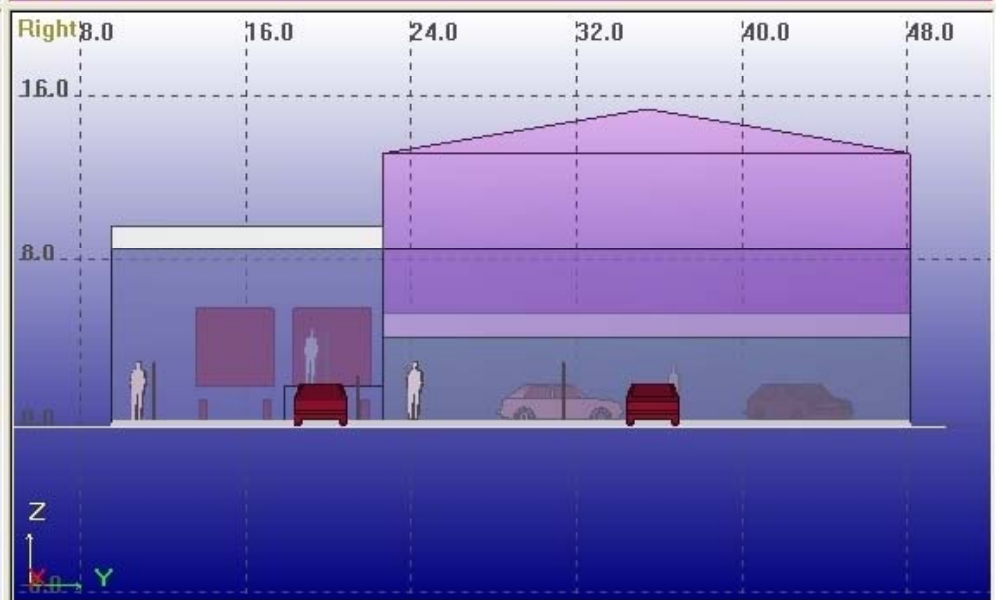
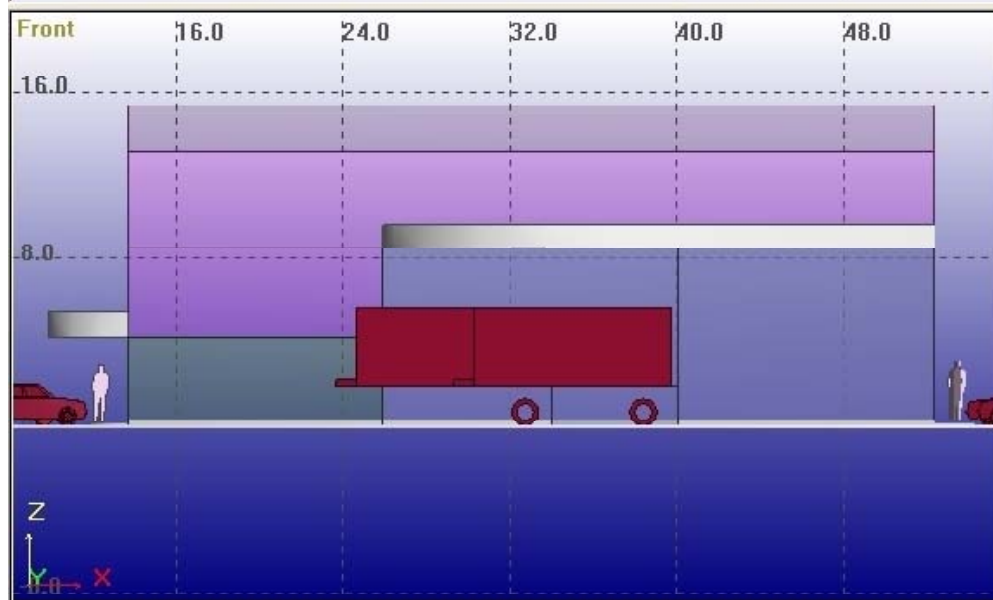
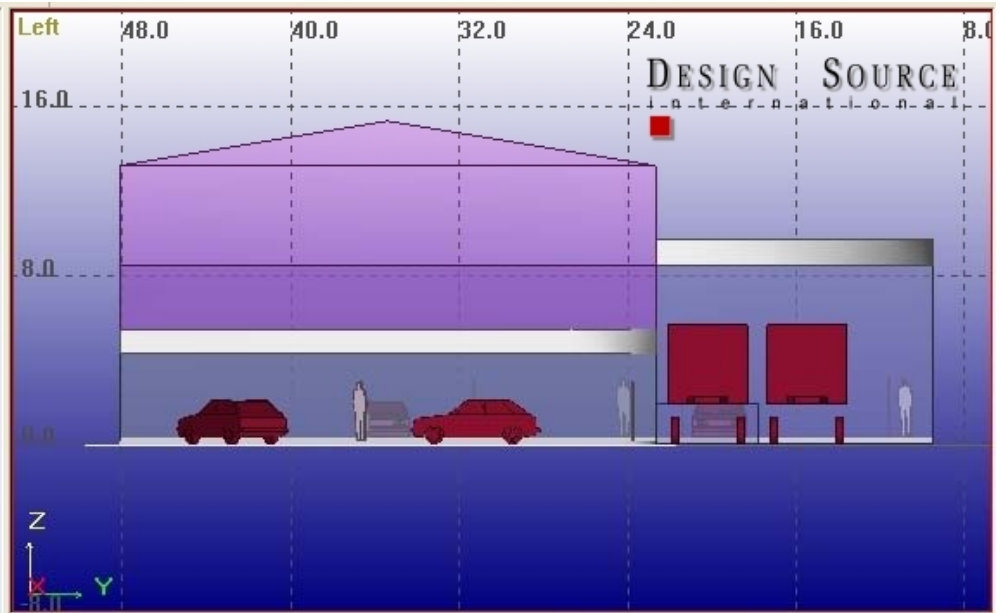
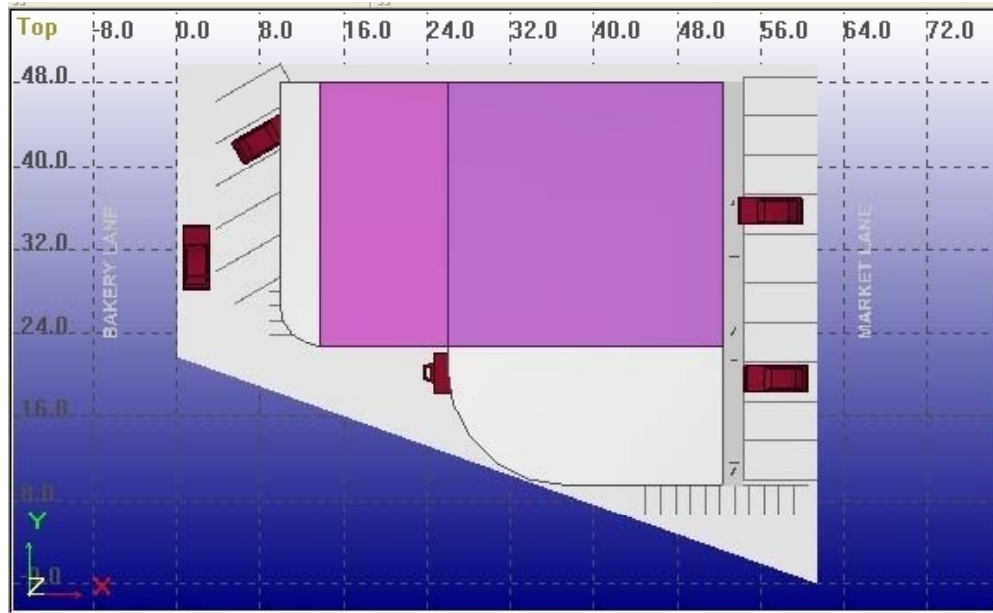

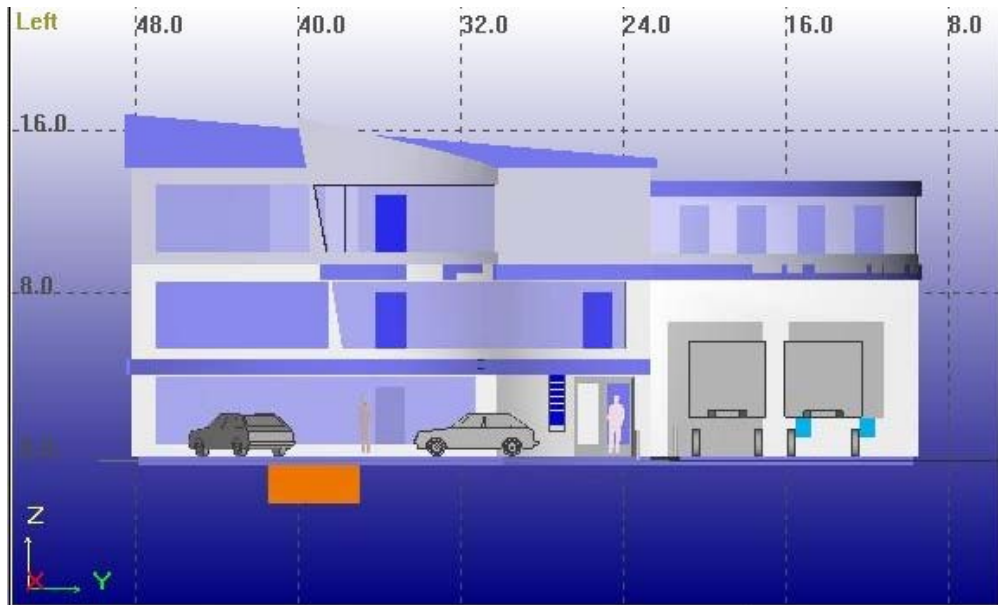

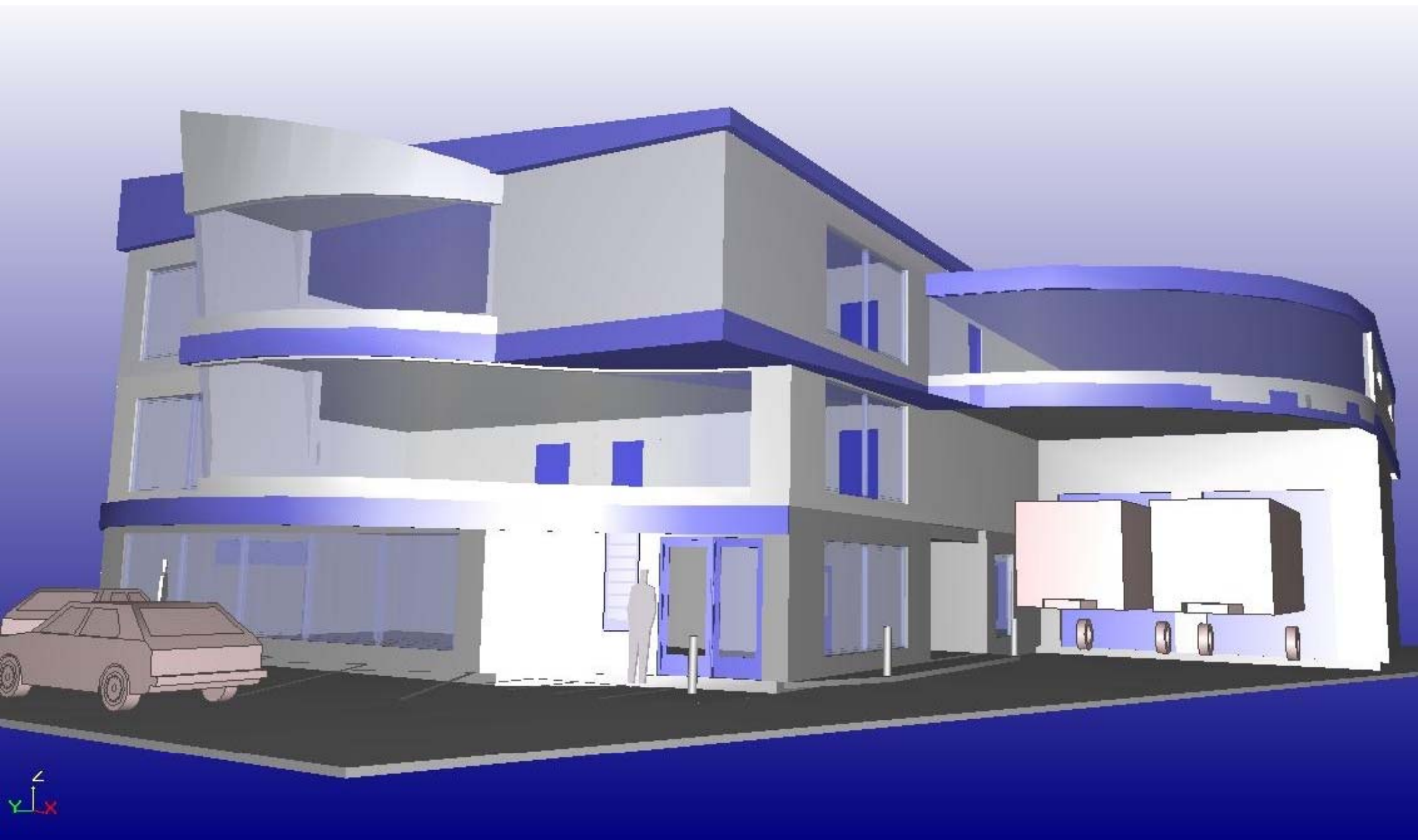





The Island Bldg

City of Hamilton

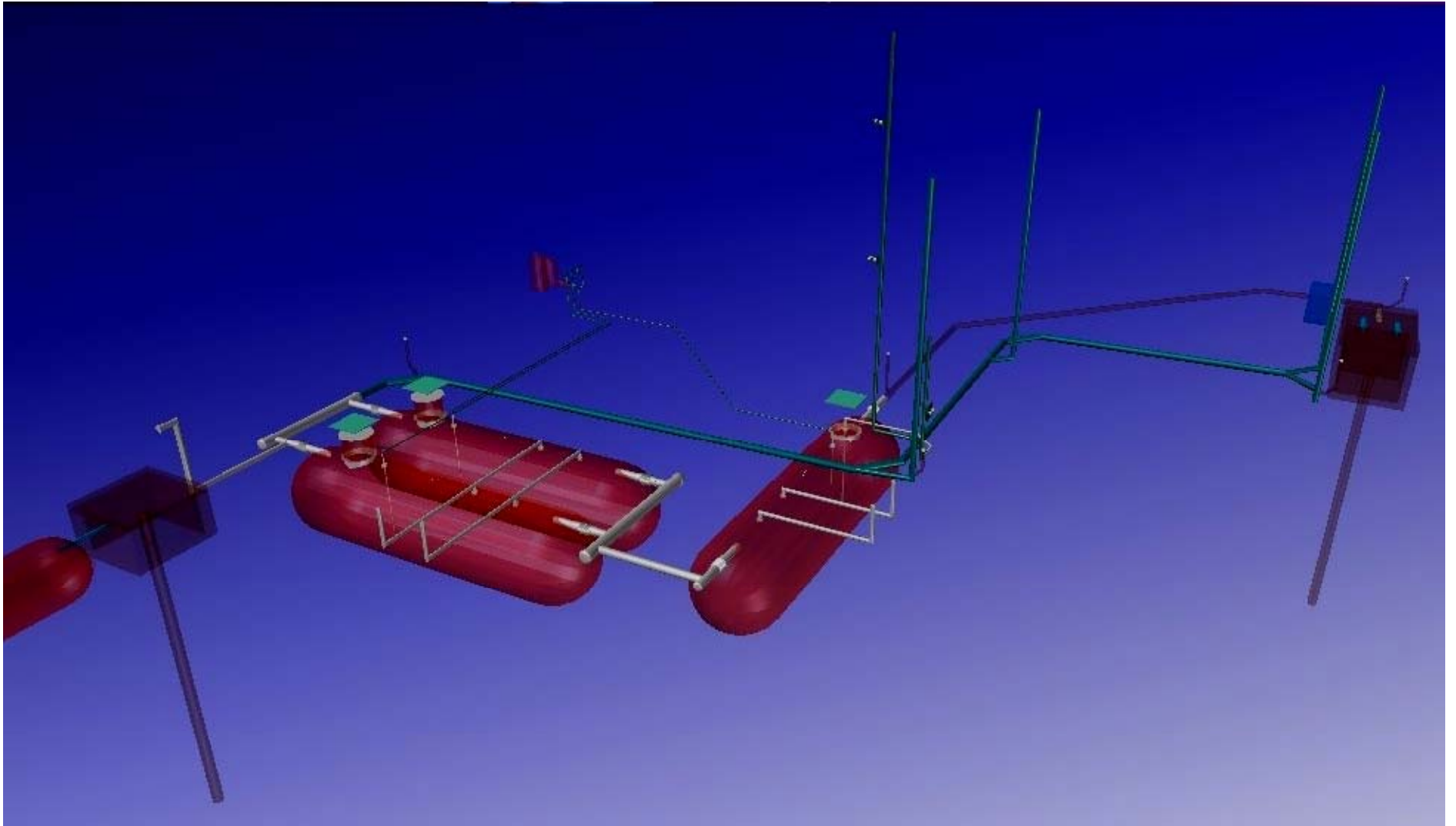



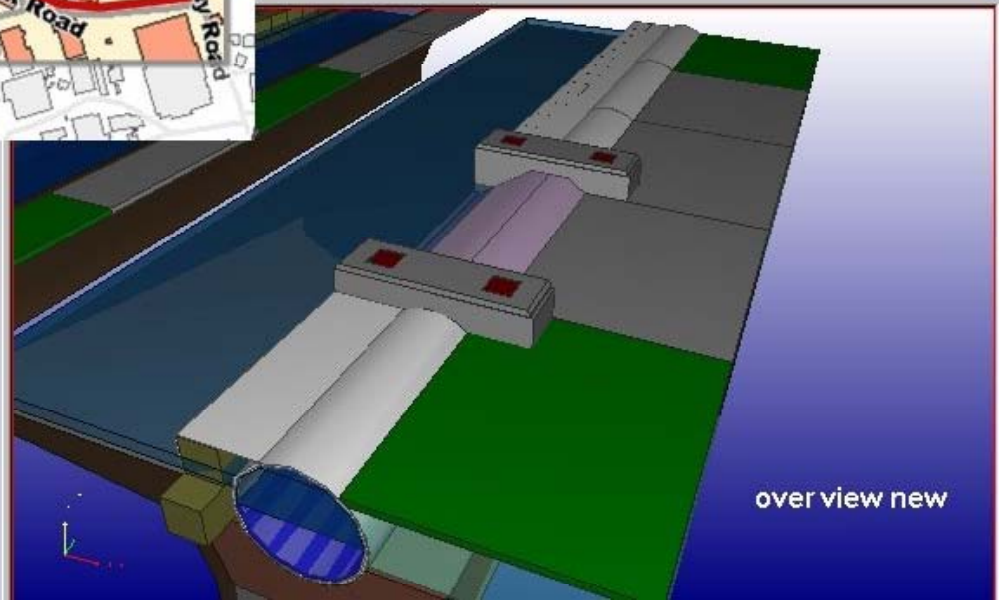
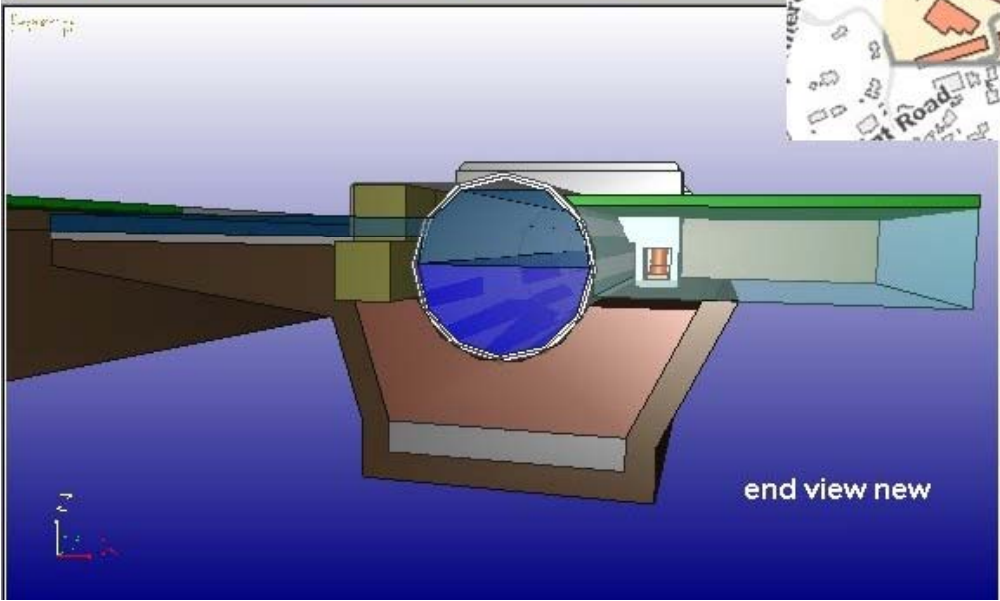
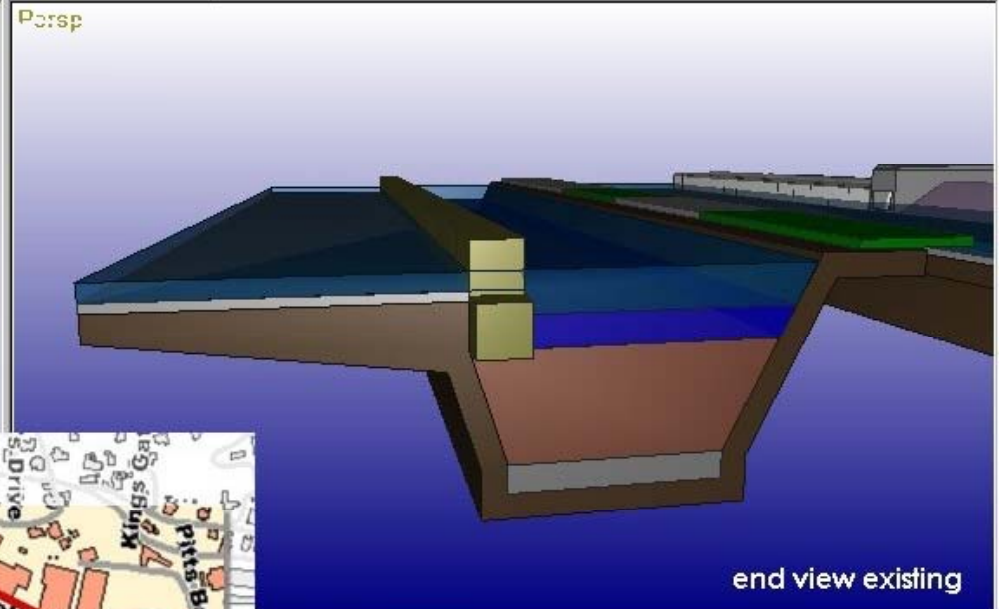
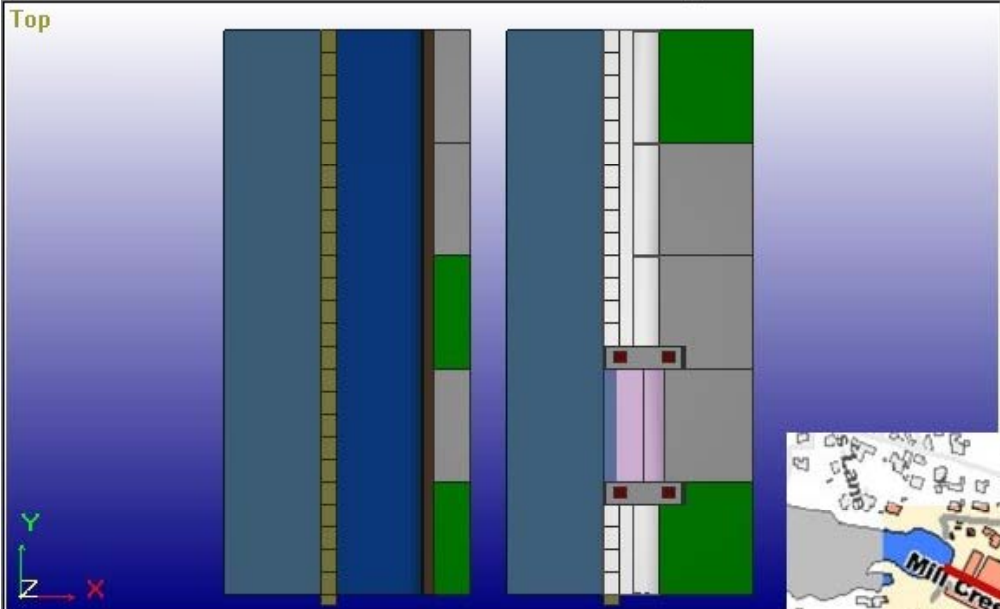

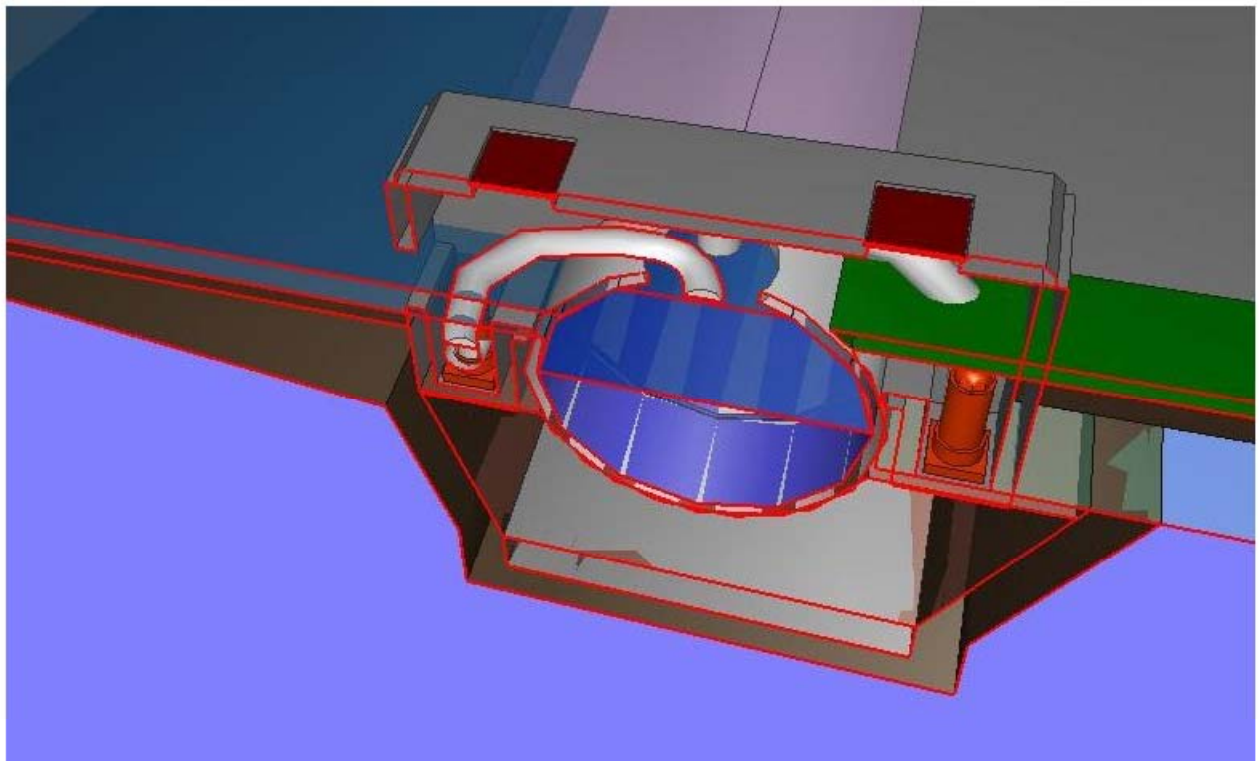
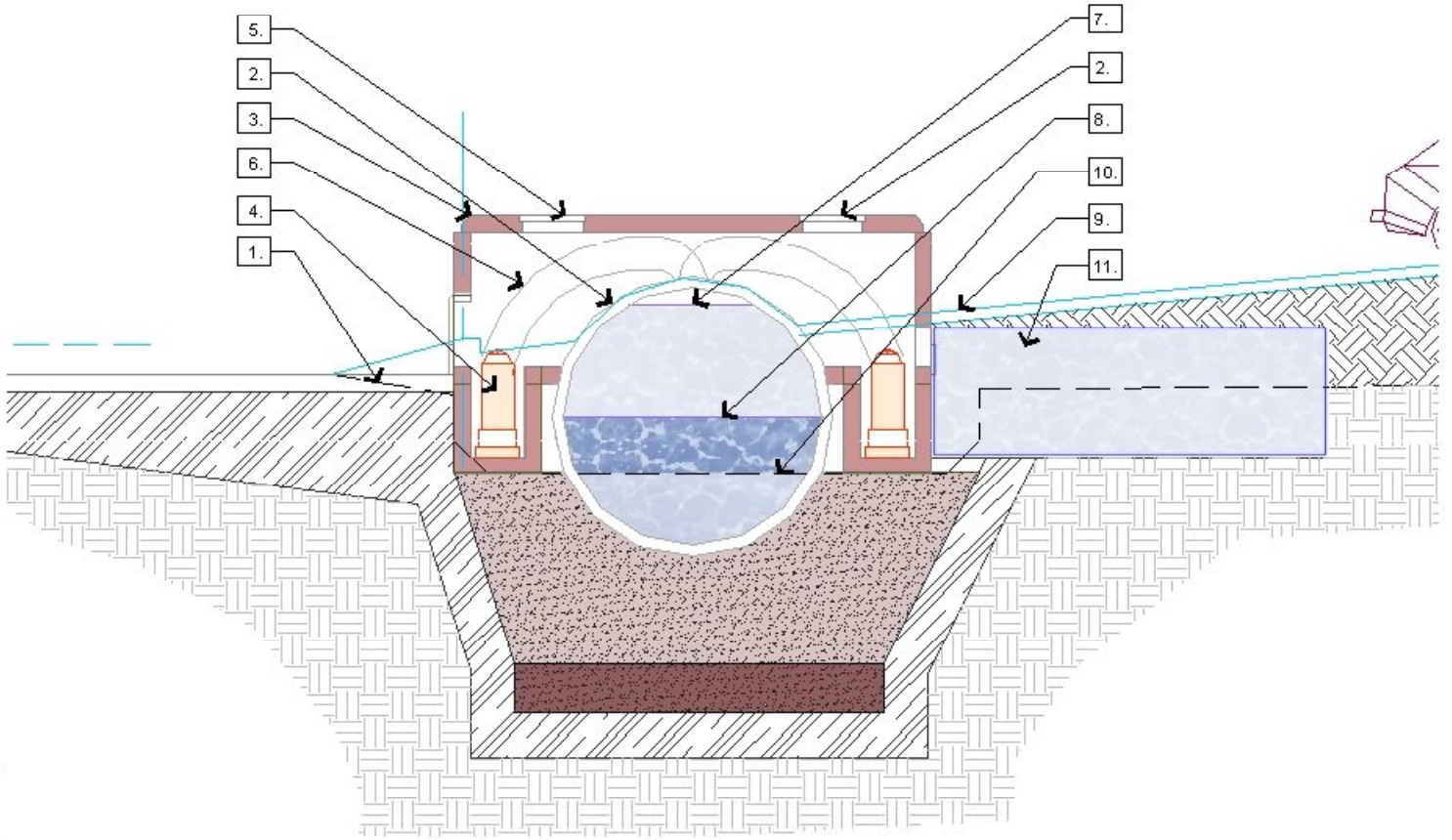

Mills Creek Storm Water
Retention and Dispersion Details

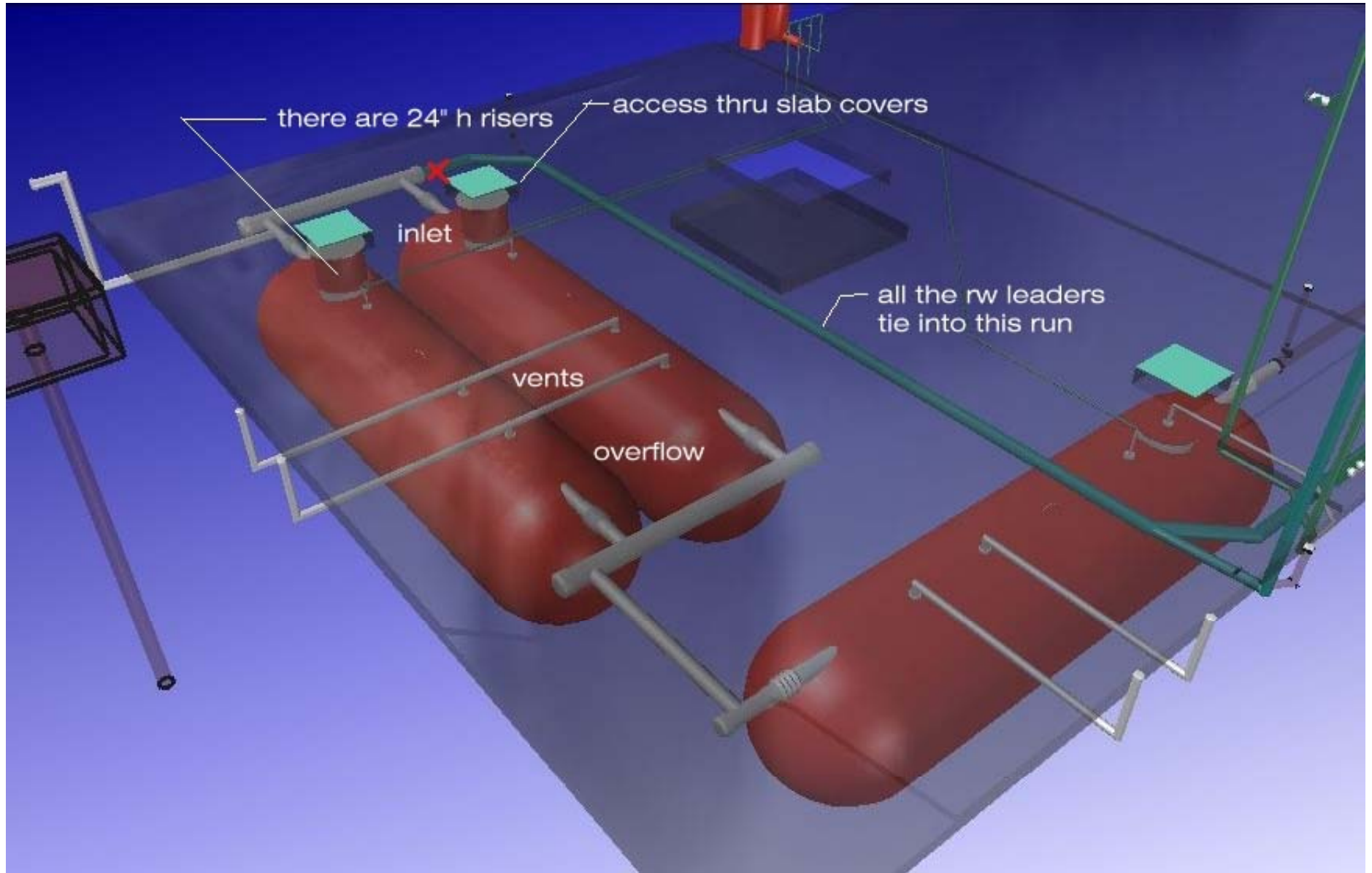

there are 24" h risers

access thru slab covers

inlet

vents

overflow

all the rw leaders tie into this run

inlet

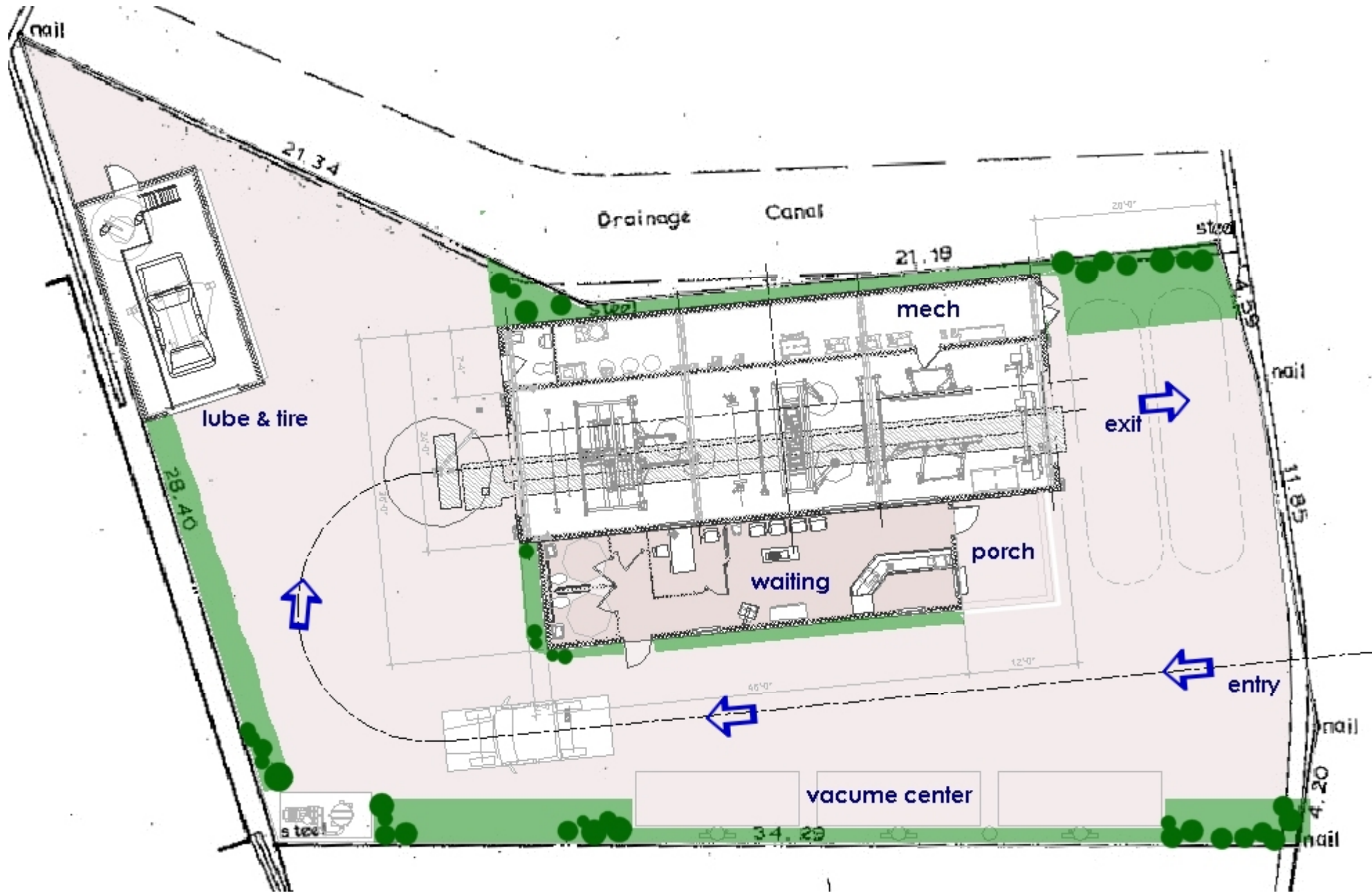

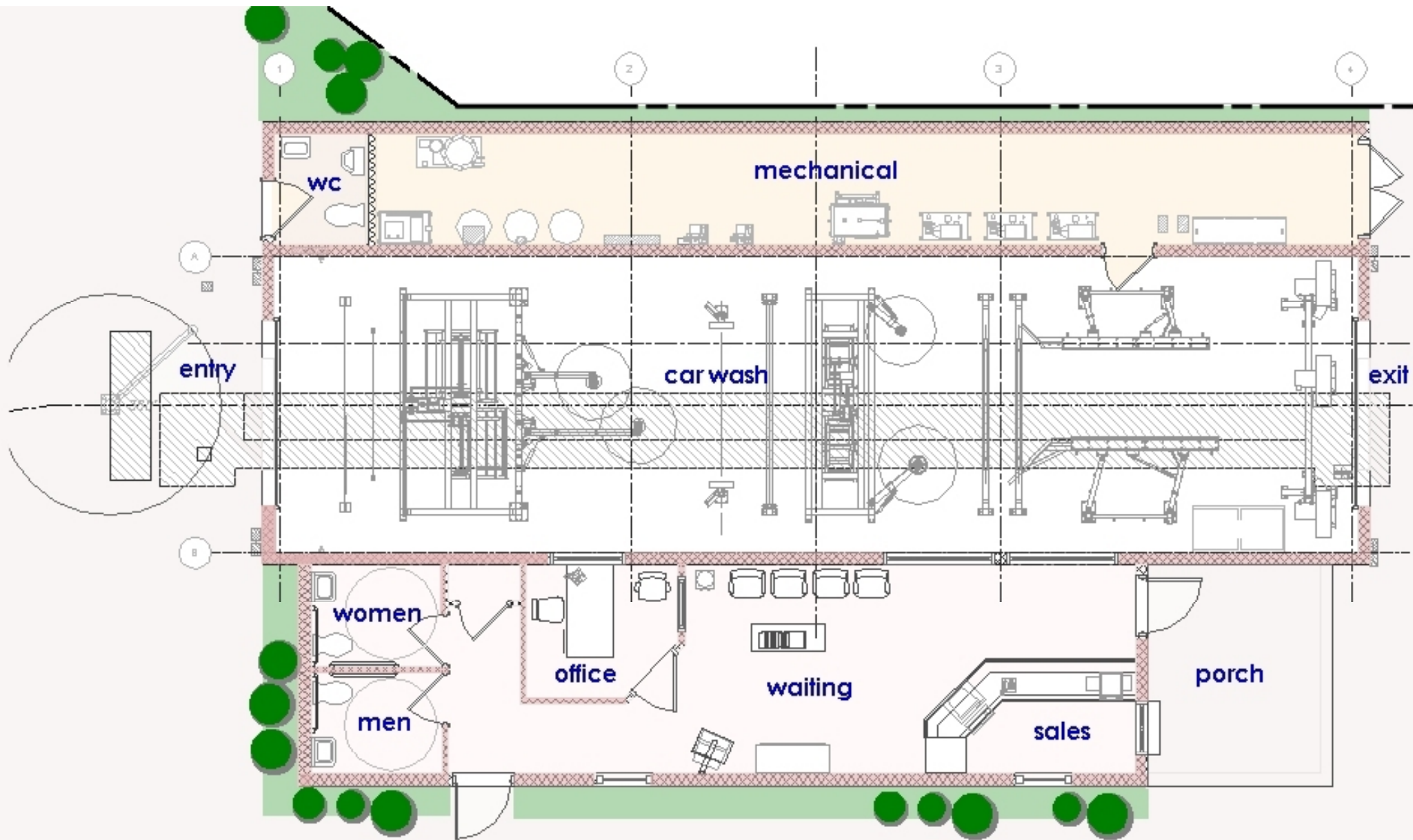

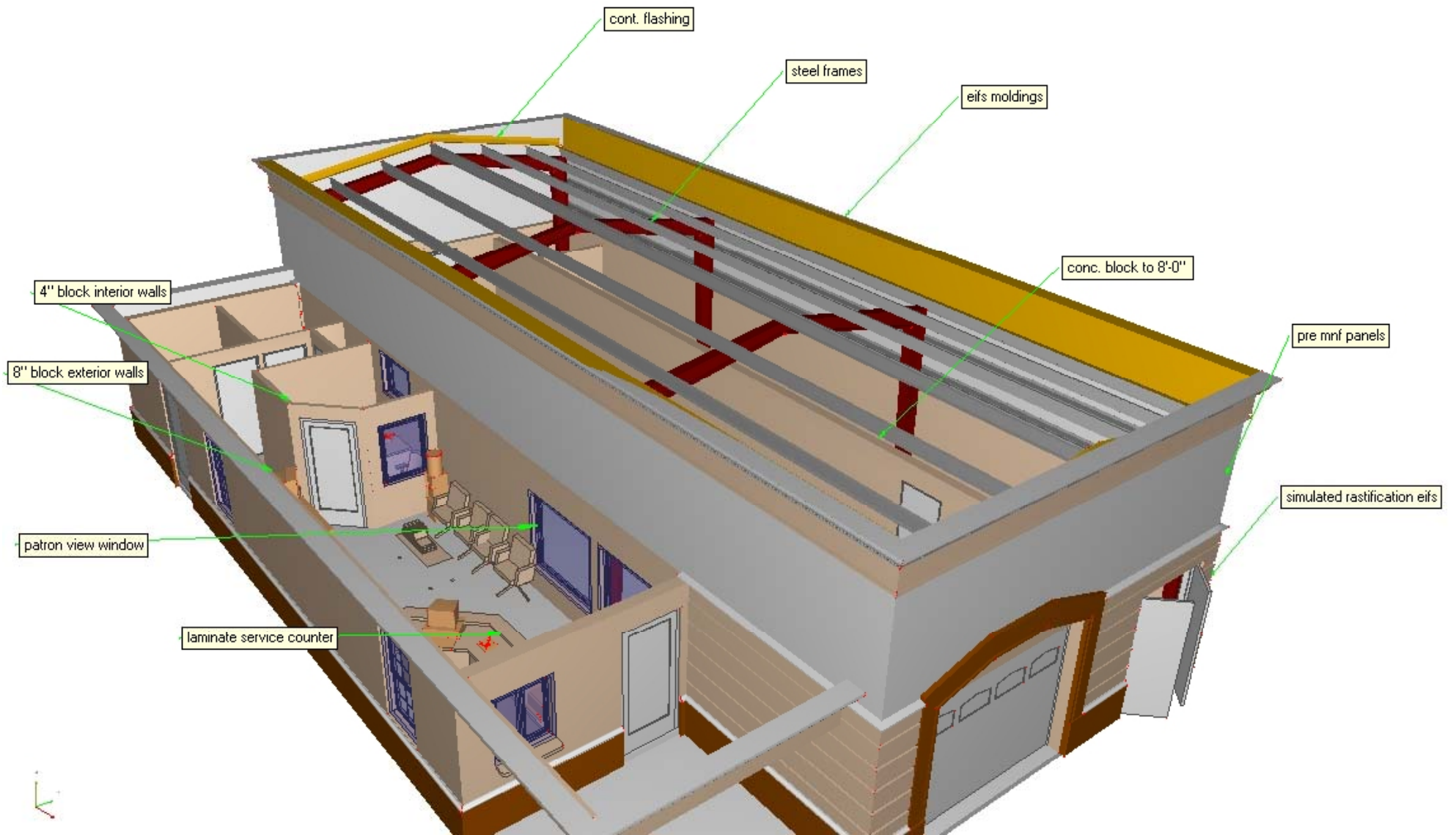



Bull's Head Care Care

City of Hamilton